



510 Madera Ave
San Jose, CA 95112
(408) 993-1900
Fax (408) 993-1944

Dear HomeGuard customer,

Thank you for selecting HomeGuard Incorporated to perform the termite inspection on your home.

It is very common for corrective work to be recommended. Enclosed you will find the inspection report that includes the findings, repair recommendations and prices to complete the repairs. Now that you have allowed us to do the inspection, we would like to point out the advantages of authorizing HomeGuard Incorporated to complete the recommended repairs.

- When HomeGuard completes the repairs, there are no additional reinspection costs. Only a licensed structural pest control company can issue a **certification** that the property is free and clear of active infestations or infection.
- HomeGuard Incorporated's bids are competitive with professional companies and all of our work is guaranteed.
- HomeGuard Incorporated's repair technicians are experts and we guarantee high quality repairs.
- HomeGuard Incorporated is sensitive to the special demands on you when a real estate transactions is involved. We make scheduling easy. We work with your Realtor, lender and title company to expedite all required paperwork.
- With HomeGuard Incorporated, you are protected. Unlike many contractors or handymen, we maintain liability insurance, errors and omissions insurance, and workman's compensation; thereby protecting you from potential lawsuits.

Please review the enclosed inspection and bids. We are available to discuss the findings and recommendations with you at your convenience. Satisfying your structural pest control needs in a professional and affordable manner is what separates HomeGuard Incorporated from the competition.

Sincerely Yours,

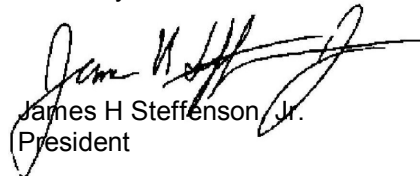

James H Steffenson, Jr.
President

WOOD DESTROYING PESTS AND ORGANISM INSPECTION REPORT

Building No. 463	Street Nolden Avenue	City San Jose	ZIP 95117	Date of Inspection 6/23/2010	Number of Pages Page 1 of 7
----------------------------	--------------------------------	-------------------------	---------------------	--	---------------------------------------



**510 Madera Ave
San Jose, CA 95112
(408) 993-1900 • Fax (408) 993-1944
Registration # PR1452**

HomeGuard Rpt #: **143148**

Ordered By: Steve Trotter Intero Real Estate 1900 Camden Avenue San Jose CA 95124	Property Owner/Party in Interest:	Report Sent to: Escrow#: 0631015785 Robin Primeau Old Republic Title 2110 S. Bascom Avenue #102 Campbell Ca 95008
---	-----------------------------------	--

COMPLETE REPORT <input checked="" type="checkbox"/>	LIMITED REPORT <input type="checkbox"/>	SUPPLEMENTAL REPORT <input type="checkbox"/>	REINSPECTION REPORT <input type="checkbox"/>
---	---	--	--

General Description: Two story, single family wood framed residence with wood and stucco exterior.	Inspection Tag Posted: Garage
	Other Tags Posted: Able 10/09

An inspection has been made of the structure(s) shown on the diagram in accordance with the Structural Pest Control Act. Detached porches, detached steps, detached decks and any other structures not on the diagram were not inspected.

Subterranean Termites <input type="checkbox"/>	Drywood Termites <input checked="" type="checkbox"/>	Fungus / DryRot <input checked="" type="checkbox"/>	Other Findings <input checked="" type="checkbox"/>	Further Inspection <input checked="" type="checkbox"/>
If any of the above boxes are checked, it indicates that there were visible problems in accessible areas. Read the report for details on checked items.				

Key to Items on diagram: [1] Section 1 Items [2] Section 2 Items [3] Unknown Further Inspection Items

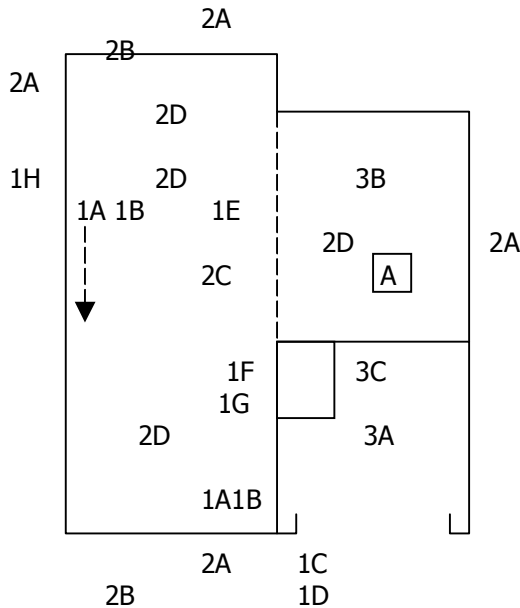

FRONT
Diagram Not To Scale

Inspected by: **Andrew m Ries**

License#: **FR40213**

Signature: _____

You are entitled to obtain copies of all reports and completion notices on this property filed with the board during the preceeding two years. To obtain copies contact: Structural Pest Control Board, 2005 Evergreen Street, Suite1500, Sacramento, California 95815-3831.

NOTE: Questions or problems concerning the above report should be directed to the manager of the company. Unresolved questions or problems with services performed may be directed to the Structural Pest Control Board at (916)561-8700, (800) 737-8188 or www.pestboard.ca.gov.

Building No. 463	Street Nolden Avenue	City San Jose	ZIP 95117	Date of Inspection 6/23/2010	Number of Pages Page 2 of 7
----------------------------	--------------------------------	-------------------------	---------------------	--	---------------------------------------

AREAS NOT INSPECTED PLEASE READ

This report is an inspection for wood destroying pests and organisms to a furnished, occupied structure. Some areas of the structure were inaccessible for inspection due to furnishings, appliances, floor covering, and/or stored personal property. We did not inspect areas immediately under furnishings or appliances, nor did we inspect inside finished walls or ceilings. Our inspection does not include any electric, heating, or mechanical systems of the structure. Our inspection will not detect building code violations. If any information is desired about any areas mentioned, a company which makes home inspections should be engaged. The plumbing was inspected and only the leaks outlined in our report were found at this time; however, we assume no responsibility for leaks that occur after the date of this inspection. There may be health related issues associated with the findings reflected in this report. We are not qualified to and do not render an opinion concerning any such health issues. The inspection reflected by this report was limited to the visible and accessible areas only. Questions concerning health related issues, which may be associated with the findings or recommendations reflected in this report, the presence of mold, the release of mold spores or concerning indoor air quality should be directed to a Certified Industrial Hygienist. This structure has carpet installed. Although no adverse conditions were evident, we assume no responsibility for the floor covering under the carpet unless we remove the carpet. The enclosed areas inside the stairs were not inspected. We did not inspect the interior of enclosed abutments or hollow stucco rails. A portion of the subfloor is insulated below the structure. There is no evidence of any infestation in these areas; however, this insulation could possibly conceal infestations. We assume no responsibility for any infestations concealed by this insulation. We did not water test nor inspect upstairs plumbing concealed by finished ceilings. As is standard practice within our industry and since our inspectors do not carry a 30' ladder on their truck, a portion of the eaves, wood siding and wood windows above 11' were only inspected visually. Upon request and at an additional charge HomeGuard Inc. will return to the property and further inspect these inaccessible areas by probing the wood members. The area of the foundation concealed behind the stucco, brick or rock wall covering was inaccessible for inspection. There is no evidence of any infestations in this area; however, this could possibly conceal termite entry points. The inaccessible areas listed above which were not inspected will be inspected upon the owner's request and may be conditional to additional inspection fees.

"This company will reinspect repairs done by others within four months of the original inspection. A charge, if any, can be no greater than the original inspection fee for each reinspection. The reinspection must be done within ten (10) working days of request. The reinspection is a visual inspection and if inspection of concealed areas is desired, inspection of work in progress will be necessary. Any guarantees must be received from parties performing repairs."

NOTE: Work performed by others will be reinspected for a fee of \$175.00 for each trip out to the property. Open wall and open floor inspections are desirable if certification is required.

NOTICE: Reports on this structure prepared by various registered companies should list the same findings (i.e. termite infestations, termite damage, fungus damage, etc.). However, recommendations to correct these findings may differ from company to company. You have the right to seek a second opinion from another company.

NOTE: WE GUARANTEE ALL REPAIRS DONE BY THIS COMPANY FOR ONE YEAR AND

Building No. 463	Street Nolden Avenue	City San Jose	ZIP 95117	Date of Inspection 6/23/2010	Number of Pages Page 3 of 7
----------------------------	--------------------------------	-------------------------	---------------------	--	---------------------------------------

FUMIGATIONS FOR A PERIOD OF 2 YEARS FROM THE DATE OF COMPLETION. WITH THE EXCEPTION OF PLUMBING, GROUTING, CAULKING AND RE-SETTING OF TOILETS WHICH ARE GUARANTEED FOR 30 DAYS FROM THE DATE OF COMPLETION. WE CANNOT GUARANTEE WORK DONE BY THE OWNER OR OWNER'S AGENT. WE MAKE NO GUARANTEE AGAINST FUTURE INFECTIONS, ADVERSE CONDITIONS, OR CONDITIONS PRESENT BUT NOT EVIDENT AT THE TIME OF OUR INSPECTION.

NOTE: THIS IS A SEPARATED REPORT WHICH IS DEFINED AS SECTION I AND SECTION II CONDITIONS EVIDENT ON THE DATE OF INSPECTION. SECTION I CONTAINS ITEMS WHERE THERE IS EVIDENCE OF ACTIVE INFESTATION, INFECTION, OR CONDITIONS THAT HAVE RESULTED IN OR FROM INFESTATION OR INFECTION. SECTION II ITEMS ARE CONDITIONS DEEMED LIKELY TO LEAD TO INFESTATION OR INFECTION BUT WHERE NO VISIBLE EVIDENCE OF SUCH WAS FOUND. FURTHER INSPECTION ITEMS ARE DEFINED AS RECOMMENDATIONS TO INSPECT AREA(S) WHICH DURING THE ORIGINAL INSPECTION DID NOT ALLOW THE INSPECTOR ACCESS TO COMPLETE HIS INSPECTION AND CANNOT BE DEFINED AS SECTION I OR SECTION II.

Section 1 Items

1A. FINDING: Infestation by Drywood Termites was noted at the subarea.

RECOMMENDATION: Due to the nature of these infestations, it will be necessary to seal the entire structure and fumigate it with Vikane (sulfuryl fluoride), using Chloropicrin as a warning agent. The entire structure must be vacant for this process. It is the owners responsibility to make any preparations required by the fumigators or to have someone to do so at a separate expense and to have the gas turned back on when the fumigation is complete. Due to current Cal OSHA Safety Standards work above 7.5 feet demands fall protection, this requires the installation of anchor points at the roof ridge line. HomeGuard will repair any damage caused by the installation of the anchor. However, in the case of metal roof coverings it is the owners responsibility to make areas on the roof ridge accessible to secure the anchors. HomeGuard Incorporated guarantees all fumigations for a period of two years.

***** (SECTION 1 ITEM) *****

1B. FINDING: Drywood termite pellets were evident as noted in the above recommendation.

RECOMMENDATION: Remove and/or mask over all accessible termite pellets. It is possible for the Drywood Termite pellets to sift down or reappear in these areas where they have been masked over.

***** (SECTION 1 ITEM) *****

1C. FINDING: Fungus damage was noted to the roof eaves as indicated on the diagram.

RECOMMENDATION: Remove and replace the damaged wood members to correct this condition. This bid includes replacement of the roof covering if disturbed by our repairs. If existing gutters need to be removed to perform the repairs then our bid also includes reinstallation of original gutters. If it becomes necessary or desirable to install new gutters this will be done only if authorized and at an additional cost. The guarantees on the roof covering are limited to the areas where the work was performed

***** (SECTION 1 ITEM) *****

Building No. 463	Street Nolden Avenue	City San Jose	ZIP 95117	Date of Inspection 6/23/2010	Number of Pages Page 4 of 7
----------------------------	--------------------------------	-------------------------	---------------------	--	---------------------------------------

1D. FINDING: Fungus damage was noted to the rafters as indicated on the diagram.

RECOMMENDATION: Remove and replace the damaged wood members to correct this condition. This bid includes replacement of the roof covering if disturbed by our repairs. If existing gutters need to be removed to perform the repairs then our bid also includes reinstallation of original gutters. If it becomes necessary or desirable to install new gutters this will be done only if authorized and at an additional cost. The guarantees on the roof covering are limited to the areas where the work was performed

***** (SECTION 1 ITEM) *****

1E. FINDING: The upstairs hall bathroom door jamb at the right side was found to be fungus damaged.

RECOMMENDATION: Remove and replace the door jamb to correct this condition.

***** (SECTION 1 ITEM) *****

1F. FINDING: The mudsill and rim joist have been damaged by fungus at the kitchen.

RECOMMENDATION: Remove and replace all the damaged wood members. If any damage is found to extend into any enclosed areas a supplemental report and bid will be issued.

***** (SECTION 1 ITEM) *****

1G. FINDING: There is a plumbing leak at the kitchen drain line.

RECOMMENDATION: Reseal or repair this leak in the most practical way.

***** (SECTION 1 ITEM) *****

1H. FINDING: The rim joist and subfloor have been damaged by drywood termites at the left side.

RECOMMENDATION: Reinforce these wood members as necessary. If damage is found to extend into inaccessible areas, a supplemental report will be issued with any findings, recommendations and bids.

***** (SECTION 1 ITEM) *****

Section 2 Items

NOTE: Ceramic tiles were noted over the kitchen, hall bathroom, master bathroom and upstairs hall bathroom floors. There is no outward sign of infestation or infection however we cannot represent the condition of floors beneath the tiled areas.

2A. FINDING: Minor stress cracks were noted in the exterior stucco as indicated on the diagram.

RECOMMENDATION: Seal all cracks that are wider than 1/16 of an inch with a exterior grade paintable sealant. If HomeGuard has supplied a bid for this item it does not include paint.

***** (SECTION 2 ITEM) *****

2B. FINDING: There is vegetation in contact with the structure.

RECOMMENDATION: The owner is advised to cut back the vegetation away from contact with the structure.

***** (SECTION 2 ITEM) *****

Building No. 463	Street Nolden Avenue	City San Jose	ZIP 95117	Date of Inspection 6/23/2010	Number of Pages Page 5 of 7
----------------------------	--------------------------------	-------------------------	---------------------	--	---------------------------------------

2C. FINDING: There is evidence of water leakage around the hall bathroom glass tub enclosure.

RECOMMENDATION: Reseal this enclosure in the most practical way. With this type of enclosure, we cannot guarantee to completely stop the leakage, only to control it. It will be the owners responsibility to maintain this enclosure in a waterproof condition.

***** (SECTION 2 ITEM) *****

2D. FINDING: There is cellulose debris in earth contact in the substructure area.

RECOMMENDATION: Remove cellulose debris of a size that can be raked from the substructure area.

***** (SECTION 2 ITEM) *****

Further Inspection Items

3A. FINDING: We were unable to inspect the interior of the garage due to stored personal property.

RECOMMENDATION: The owner should move the storage away from the garage walls to allow for further inspection. All findings, recommendations, and bids will be issued in a supplemental report.

***** (FURTHER INSP ITEM) *****

3B. FINDING: The subfloor was insulated. This conceals the wood members of the substructure. Further inspection recommended.

RECOMMENDATION: Remove the insulation from the perimeter of the structure and at all water pipe penetrations or from areas where fungus was noted, inspect the exposed wood members, and issue a supplemental report listing all findings, recommendations, and bids. Reinstall the insulation where removed upon completion.

***** (FURTHER INSP ITEM) *****

3C. FINDING: The master bathroom was locked and inaccessible for inspection.

RECOMMENDATION: The owner is to provide access to the master bathroom for further inspection. Upon further inspection, a supplemental report will be issued listing all findings, recommendations and bids.

***** (FURTHER INSP ITEM) *****

NOTE: This property has recently been painted. We assume no responsibility for any infestations or infections that may be concealed by this fresh paint.

NOTE: "State law requires that you be given the following information:

CAUTION-PESTICIDES ARE TOXIC CHEMICALS. Structural Pest Control Companies are registered and regulated by the Structural Pest Control Board, and apply pesticides which are registered and approved for use by the California Department of Food and Agriculture and the United States Environmental Protection Agency. Registration is granted when the state finds that based on existing scientific evidence there are no appreciable risks that are outweighed by the benefits. The degree of risk depends upon the degree of exposure, so exposure should be minimized."

"If within 24 hours following application, you experience symptoms similar to common seasonal illness comparable to the flu, contact your physician or poison control center and your pest control company immediately."

For further information contact any of the following:

Building No. 463	Street Nolden Avenue	City San Jose	ZIP 95117	Date of Inspection 6/23/2010	Number of Pages Page 6 of 7
----------------------------	--------------------------------	-------------------------	---------------------	--	---------------------------------------

HOMEGUARD INCORPORATED (408) 993-1900
 Poison Control Center: (800) 876-4766
 Santa Clara County Agricultural Commission (408) 918-4600
 Santa Clara County Health Department (408) 918-3400
 San Benito County Health Department (831) 637-5367
 San Benito County Agricultural Commission (831) 637-5344
 Alameda County Agricultural Commission (510) 670-5232
 Alameda County Health Department (510) 267-8000
 Contra Costa County Agricultural Commission (925) 313-6712
 Contra Costa County Health Department (925) 646-5137
 San Mateo County Agricultural Commission (650) 363-4700
 San Mateo County Health Department (650) 573-2757
 Structural Pest Control Board (800) 737-8188
 2005 Evergreen Street Ste. #1500, Sacramento, CA 95815-3831

"Local treatment is not intended to be an entire structure treatment method. If infestations of wood-destroying pests extend or exist beyond the area(s) of local treatment, they may not be exterminated".

- NOTE: Unless stated otherwise HomeGuard Incorporated bids include texturing and painting repaired areas. We will cover repaired sheetrock and wood with one (1) coat of white primer or (1) coat of color supplied by the owner. Any texturing will vary from original texture however we will match as close as possible. All painting will be on the area repaired only feathering the paint in to blend with existing. On exterior surfaces texturing and painting will only be done weather permitting.
- NOTE: Unless prior arrangements have been made, white tile will be installed. It should also be noted that all tile work, regardless of color selection, will be done with a tight white grout joint.
- NOTE: If damage is found to extend into any inaccessible areas, a supplemental report will be issued listing additional findings, recommendations and bids.
- NOTE: Should the further inspection items noted in this report not be performed, HomeGuard Incorporated will assume no liability for any infestations or infection which may be concealed in these areas.
- NOTE: If any of the wood repairs outlined in the above report are done by others, an open inspection must be performed by this company if the appropriate certification is desired.
- NOTE: Due to the building materials used on this structure, it may be difficult to match the existing mill patterns and materials used in the original construction. We will replace damaged wood members with material which resembles, as closely as possible, the existing wood members with standard grade, readily available wood members.
- NOTE: Should the local building department require additional changes or repairs not outlined in this report, additional funds will be required.
- NOTE: EXTERIOR SURFACE OF THE ROOF WAS NOT INSPECTED. IF YOU WANT THE WATER TIGHTNESS OF THE ROOF DETERMINED, YOU SHOULD CONTACT A ROOFING CONTRACTOR WHO IS LICENSED BY THE CONTRACTORS STATE LICENSE BOARD.
- NOTE: Thank you for using HomeGuard Incorporated. If you have any questions regarding this report, please call and ask for Andrew Ries. Please bear in mind that the inspectors have

Building No.	Street	City	ZIP	Date of Inspection	Number of Pages
463	Nolden Avenue	San Jose	95117	6/23/2010	Page 7 of 7

full schedules during the day and can only be reached by phone early in the morning and late in the afternoon. The inspector will make every effort to make contact with you when he is available.

If you require further assistance or wish to schedule work as recommended in this report, please feel free to contact our office. We are here to assist you!

Fact Sheet for Vikane* (Sulfuryl Fluoride)

In the interest of DowElanco's commitment to product stewardship, this fact sheet is intended to provide basic information and how it is used. If you have additional questions about Vikane or the procedures described, call the DowElanco Customer Information Service at 1-800-352-6776.

WHY BUILDINGS ARE FUMIGATED

Insects that feed or tunnel into wood can seriously damage houses, apartments, and other dwellings or structures. Each year termites or other wood destroying insects damage approximately 2 million homes. Depending on the extent or location of the infestation, fumigation is the only total control method proven to eliminate certain infestation of wood destroying insects.

HOW BUILDINGS ARE FUMIGATED

Because Vikane is a gas, prior to fumigation the structure is completely sealed. This serves to contain Vikane in the building so it can penetrate wood thoroughly and eliminate the pests. Depending on the construction of the building, the doors and windows may be sealed with tape and a plastic sheet, or the structure may be covered with a tarp. The building will remain sealed for 4 to 72 hours depending on the specifics of the job. Warning signs are posted around the building notifying people to keep out.

After the tarp or tape is removed, a professional fumigator will aerate the structure by opening the doors and windows. Fans may also be used to clear out the building. Once the building has been thoroughly aerated, the fumigator is required to measure the level of any fumigant remaining in the living space to ensure it is below the established safe re-entry concentration. Your building should not be cleared for re-occupancy until it is safe to enter. The fumigator will post a notice on your building indicating the day and time for re-entry. Structures can be occupied only when the concentration is 5 parts per million or less (this represents a margin of safety – laboratory animals have been exposed to 100 parts per million for 2 weeks with no adverse effects). Because Vikane is a true gas and not a vapor, aeration is rapid. Recent studies demonstrated that in most structures levels are less than 1 part per million within 6 hours of clearing and have no detectable levels of Vikane within 24 hours after the start of aeration.

Sulfuryl Fluoride is a colorless, odorless gas, so a warning agent is added to the building, which causes watery eyes and a scratchy throat. If you experience these symptoms in a structure that has been recently fumigated, you should leave immediately and call the pest control company to have your building re-tested.

SULFURYL FLUORIDE (POTENTIAL HEALTH RISK FROM OVEREXPOSURE)

Sulfuryl Fluoride is a gas and can potentially enter your body through inhalation. Because it is a gas, it does not stay on dry surfaces; therefore, there is no exposure from touching treated surfaces

Nervous system and respiratory irritation:

Overexposure to high levels of Sulfuryl Fluoride can result in nose and throat irritation and nausea. At high concentrations (such as those used during the fumigation), can cause excess fluid in the lungs, sleepiness, pneumonia, and convulsions. These symptoms would be expected to appear within 8 hours after such as exposure. In the unlikely event you experience these symptoms in a building that has been recently fumigated, you should leave immediately. Consult your physician and call the pest control company to have your building re-tested.

Additional studies:

Sulfuryl Fluoride has not been shown to cause birth defects in pregnant animals exposed under experimental conditions. In addition, current studies have demonstrated there are no mutagenic or genotoxic effects caused by exposure to Sulfuryl Fluoride.

Safety Precautions and Homeowner Preparation

- Discuss the treatment program in advance with your pest control company so you fully understand what will be done and what you need to do.
- Carefully follow the instructions you are given about what items you are to remove from your building.
- If you are interested or concerned, you should ask your pest control company to show the records of how your building was aerated before it was cleared for re-entry.
- You may wish to increase ventilation by opening doors and windows.
- Call DowElanco Customer Information Service at 1-800-352-6776 if you need additional information or have questions concerning the product.

*Trademark of DowElanco



510 Madera Ave
 San Jose, CA 95112
 (408) 993-1900
 Fax (408) 280-2763

Initials _____

AGREEMENT
 463 Nolden Avenue, San Jose

HomeGuard Incorporated is authorized to proceed with the work outlined in items _____ of their termite report no. 143148 for the property located at 463 Nolden Avenue, San Jose for a total sum of \$_____. This amount will be due and payable upon completion of work. It is understood that the contract price does not include the charge of the structural pest control inspection report or re-inspection fees.

HOMEGUARD INCORPORATED AGREES

1. To guarantee all repairs completed by this company for one year from the date of completion except for plumbing, grouting, caulking, and resetting of toilets, which will be guaranteed for 30 days.
2. To be bound to perform this work for the price quoted in our cost breakdown for a period not to exceed 30 days
3. To use reasonable care in the performance of our work but to assume no responsibility for damage to any hidden pipes, wiring, or other facilities or to any, plant life, rain gutters, roofs; nor for damage or dirtying of stucco, plaster, paint, wall paper or other "finish-work" adjacent to areas where work is performed.
4. To replace damaged wood members with material which resembles, as closely as possible, the existing wood members with standard grade, readily available wood members.

OWNER OR OWNER'S AGENT AGREES:

1. To pay for services rendered upon completion of work. This contract may be canceled at any time by the customer. In the event of such action, customer agrees to pay HomeGuard Incorporated in full for all items already completed, and time and material for all items only partially completed. Time and material is calculated at the rate of ninety-five dollars per hour and the cost of materials plus 15%. The customer also agrees that in the case of cancelation of the contract, to pay all fees for nessasary permits and any associated cost for obtaining permits. In the case of non-payment by owner, reasonable attorney fees and costs of collection shall be paid by the owner whether suit be filed or not.
2. To pay for service charge of 1.5 percent per month or portion of any month beyond 30 days after completion.
3. Owner grants HomeGuard Incorporated, a security interest in the above described real property to secure payment of the sum for work and inspeciton fee completed.
4. If additional damage is discovered by HomeGuard Incorporated, during the performance of work, company agrees to notify owner or agent of the amount of the damage and the cost of additional work to be done. This work will not be performed unless owner agrees.
5. If any additional work, plans or engineering is deemed necessary by the local building inspector, said work will not be performed without additional authorization from owner or owner's agent.
6. All plumbing repairs bid in this report are for only the specific repair that is identified. Many times when performing plumbing repairs it becomes necessary to repair or replace adjacent plumbing because of the age or fragility of these components. When this happens the owner or agent will be notified and said repairs will require additional cost and authorization.

This job has been bid as if all section one items are being performed. If the owner would like to select individual items, it may require HomeGuard Incorporated to provide a new bid for these items. The minimum service charge is \$225 regardless of the bid on the individual item.

Section 1:

1A	\$1,960	1B	\$250	1C	\$300	1D	\$200	1E	\$200	1F	WillBid	1G	OthTrd
1H	\$580												

Section 2:

2A	Owner	2B	Owner	2C	\$125	2D	\$225
----	-------	----	-------	----	-------	----	-------

Further Insp:

3A	N/C	3B	T&M	3C	N/C
----	-----	----	-----	----	-----

IS UPGRADING OR CHOICE OF LINOLEUM OR TILE DESIRED? Yes___ No___

***If there is no choice, neutral colors will be installed there may be additional charges for special materials chosen**



510 Madera Ave
San Jose, CA 95112
(408) 993-1900
Fax (408) 280-2763

AGREEMENT
463 Nolden Avenue, San Jose

The charge for service that this company subcontracts to another registered company may include the company's charges for arranging and administering such services that are in addition to the direct costs associated with paying the subcontractor. You may accept HomeGuard Incorporated's bid or you may contract directly with another registered company licensed to perform the work.

If you choose to contract directly with another registered company, HomeGuard Incorporated will not in any way be responsible for any act or omission in the performance of work that you directly contract with another to perform.

NOTICE TO OWNER

Under the California Mechanics Lien law, any structural pest control operator who contracts to do work for you, any contractor, subcontractor, laborer, supplier or other person who helps to improve your property, but is not paid for work or supplies, has the right to enforce a claim against your property. This means that after a court hearing, your property could be sold by a court officer and the proceeds of the sale used to satisfy the indebtedness. This can happen even if you have paid your contractor in full if the subcontractor, laborers of suppliers remain unpaid. To preserve their right to file a claim of lien against your property, certain claimants such as subcontractors and material suppliers are required to provide you with a document intitled "Preliminary Notice". General contractors and laborers for wages do not have to provide this notice. A Preliminary Notice is not a lien against your property. Its purpose is to notify you of persons who may have a right to file a lein against your property if they are not paid. You can protect yourself from such claim by requiring your contractor to supply you with a payment and performance bond prior to commencing any work of improvement and/or requiring your contractor to provide you with an unconditional lien release signed by each material supplier, subcontractor, and laborer involved in that project phase before making payment on the completed phase of the project.

OWNER OR OWNERS AGENT DATE BY: _____, HomeGuard Incorporated

X _____ ESCROW OFFICER: _____

Print Name _____ ESCROW PHONE NO: _____

X _____ ESCROW CO/NO: _____

Print Name _____

Name of person providing access _____ Phone Number _____

THIS AGREEMENT IS 2 PAGES
PLEASE BE SURE TO SIGN AND SEND BOTH PAGES



510 Madera Ave
San Jose, CA 95112
(408) 993-1900
Fax (408) 993-1944

Invoice

Invoice Date: **6/25/2010**
Invoice No: **SJ276807T**

Bill To:	
Robin Primeau Old Republic Title 2110 S. Bascom Avenue #102 Campbell Ca 95008	
Property Information:	
Address:	463 Nolden Avenue San Jose CA, 95117
Report No.	143148TPR
Escrow#:	0631015785
Billing Information:	
Inspection: 6/23/2010 Complete	\$275.00
Notice of Completion:	\$0.00
Other:	\$0.00
Total Due:	\$275.00

DUE UPON RECEIPT
Please remit to 510 Madera Ave., San Jose, CA 95112
There is a \$25 fee for all returned checks